

THE HFA INSTITUTE 2024

Buy America, Build America



National Council of
State Housing Agencies



**MRBs and
Other Federal
Homeownership
Programs**
JANUARY 10 – 12

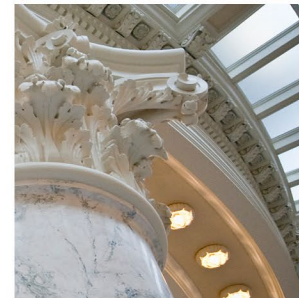

Housing Credit
JANUARY 9 – 11



**Section 8 and
Other Federal
Multifamily
Programs**
JANUARY 10 – 12

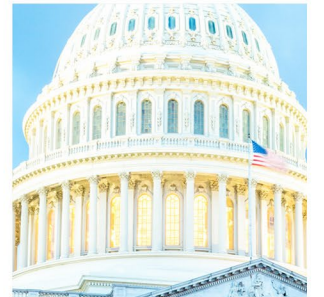

**HOME and
Housing Trust
Fund**
JANUARY 7 – 9



SPEAKER

Sara Hernandez

Senior Confidential Assistant | Office of Community Planning and Development
U.S. Department of Housing and Urban Development



Build America, Buy America Act

CPD Updates for the HFA Institute

January 8, 2024



Agenda

- BABA Overview
- Key Concepts
 - Buy America Preference (BAP) Applicability to CPD Programs
 - Product Classification & Implementation Dates
 - HUD General Waivers
 - HUD Project-/Product-Specific Waivers
 - Compliance and Recordkeeping
- Applying the BAP Analysis
- FAQ's and Resources





BABA Overview

What is the Build America, Buy America Act (BABA)?

- Enacted as part of the Infrastructure Investment and Jobs Act signed by President Biden on November 15, 2021.
- The Build America, Buy America Act (BABA) requires that certain materials purchased in connection with infrastructure projects funded by Federal financial assistance programs must be produced in the United States.
 - This requirement is known as the **“Buy America Preference (BAP).”**
- BABA regulations are encoded at 2 CFR 184.
- Notice CPD-23-12 provides implementation guidance for CPD grantees.



What is the Build America, Buy America Act (BABA)?

- The following materials used in Federally funded infrastructure projects must be produced in the United States:
 - **Iron and steel;**
 - **Manufactured products;** and
 - **Construction materials.**
- An infrastructure project is defined as any project that includes **construction, alteration, maintenance, or repair** of:
 - Buildings and real property
 - Utilities
 - Water systems (drinking water and wastewater)
 - Electrical transmission facilities and systems
 - Broadband infrastructure
 - Transportation infrastructure



Why is the Build America, Buy America Act (BABA) Important?

- **Purposes of Build America, Buy America Act**
 - Stimulate private sector investments in American manufacturing.
 - Bolster critical American supply chains.
 - Support the creation of jobs so that America's workers and firms can compete and lead globally for years to come.
- Government-wide law applicable to all Federal infrastructure spending.





BAP Applicability to CPD Programs

Federal Financial Assistance

- BABA applies to all **Federal financial assistance** used for an infrastructure project, including:
 - Grants,
 - Cooperative agreements,
 - Non-cash contributions or donations of property,
 - Direct assistance,
 - Loans,
 - Loan guarantees, and
 - Other financial assistance



BAP Applicability to CPD Funding

- The BAP applies to most CPD programs.

Community Development Block Grants (CDBG)	Self-Help Homeownership Opportunity Program (SHOP)
Section 108 Loan Guarantee	Special NOFA for unsheltered and rural homelessness
HOME Investment Partnerships Program (HOME)	Veterans Housing Rehabilitation and Modification Program (VHRMP)
HOME Investment Partnerships Program- American Rescue Plan (HOME-ARP)	Community Project Funding (CPF)/Economic Development Initiatives (EDI)
Housing Trust Fund (HTF)	Section 4 Capacity Building
Recovery Housing Program (RHP)	Rural Capacity Building
Emergency Solutions Grants (ESG)	Pathways to Removing Obstacles to Housing (PRO Housing)
Continuum of Care (CoC)	Preservation and Reinvestment Initiative for Community Enhancement (PRICE)
Housing Opportunities for Persons with AIDS (HOPWA)	FY23 Permanent Supportive Housing (PSH) Funds



CPD Exemptions from BAP

- The BAP **does not apply** to Federal financial assistance used for pre- or post-disaster assistance or emergency response.
- The BAP does not apply to the following CPD programs:
 - Community Development Block Grant – Disaster Recovery (CDBG-DR)
 - Community Development Block Grant – Mitigation (CDBG-MIT)
 - Community Development Block Grant – National Disaster Resilience Competition (CDBG-NDR)
 - Community Development Block Grant CARES Act (CDBG-CV)
 - Housing Opportunities for Persons with AIDS CARES Act (HOPWA-CV)
 - Emergency Solutions Grants CARES Act (ESG-CV)



What Projects are Covered?

Examples of CPD-funded activities that may be subject to the BAP:

- Rehabilitation or conversion of buildings and real property
- Construction of public facilities and improvements, such as streets, sidewalks, and neighborhood centers
- Utility installation or improvements
- Water systems (drinking water and wastewater)
- Electrical transmission facilities and systems
- Broadband infrastructure
- Transportation infrastructure

Examples of CPD-funded activities that may NOT be subject to the BAP:

- Acquisition of real property
- Relocation and demolition
- Public services
- Shelter or public facility operating expenses
- Supportive services
- Short-term payments to prevent homelessness
- Special economic development activities
- Administrative activities
- Disaster and emergency response





Product Classification and Phased Implementation

Product Classification

- The Buy America Preference applies to:

Iron and Steel

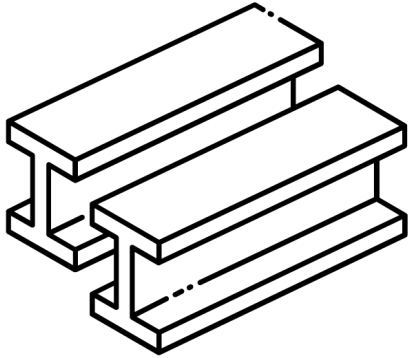

Construction Materials

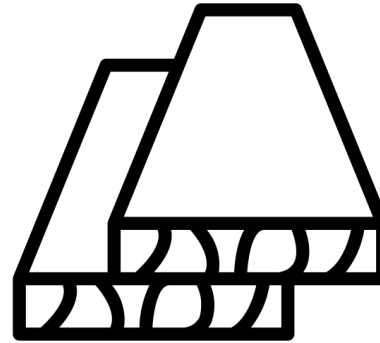

Manufactured Products

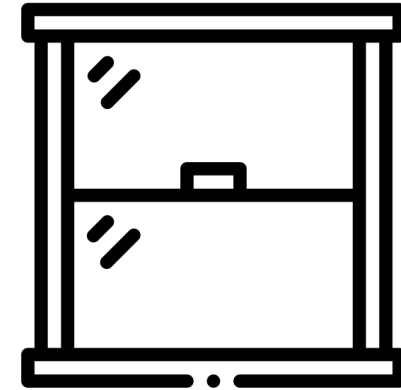

- Grantees should classify products into **one** of these categories. A product cannot be classified in more than one category.
- Grantees should classify products based on their status when they arrive at the project site.



Iron and Steel

Definition

- Items consisting completely or predominantly of iron or steel.
 - “Predominantly” means that the cost of the iron and steel content exceeds 50% of the total cost of the product’s components.

Production Requirements

- All manufacturing, from initial melting through application of coatings, must occur in the United States.

Examples

- Rebar
- Steel playground slide

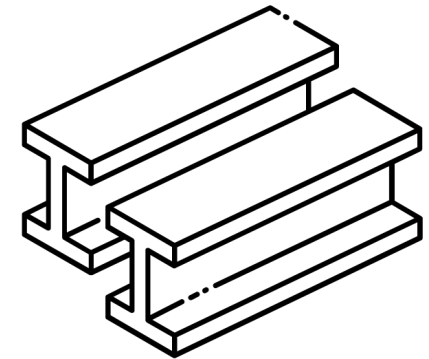

Construction Materials

For HUD programs, construction materials are divided into two categories:

Specifically Listed Construction Materials

- Non-ferrous metals
- Lumber
- Plastic- and polymer-based composite building materials, pipe, and tube

Not Listed Construction Materials

- All other plastic- and polymer-based materials
- Glass
- Fiber-optic cables
- Optical fiber
- Engineered wood
- Drywall

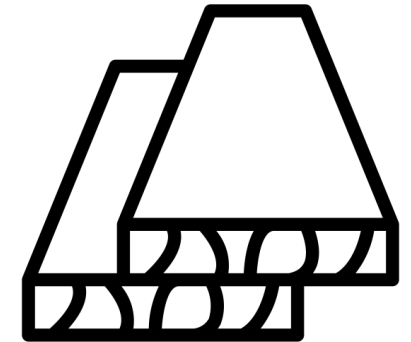

Production Requirements

- All manufacturing processes must occur in the United States.
- Minor additions of materials or binding agents to a construction material do not change the categorization of the material.



Manufactured Products

Definition

- Materials that have been processed into a specific form or shape **OR**
- Materials combined with other items to create a product with different properties.

Production Requirements

- The final product must be manufactured in the United States **AND**
- At least 55% of the cost of the product must come from components that were mined, produced, or manufactured in the United States.

Examples

- Pre-fabricated window (combines glass and fiberglass)
- Precast concrete (processed into a specific form before arriving at job site)

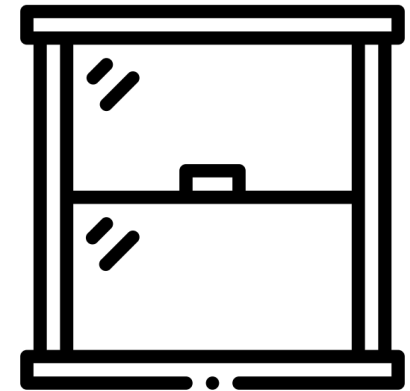

HUD Phased Implementation of BABA

- The Phased Implementation waiver published on March 15, 2023, establishes the following implementation schedule for HUD programs.
- Note: The waiver does not apply to FFA to Tribes, which is covered by a separate waiver.

BAP will apply to...	Iron and Steel	Specifically Listed Construction Materials	Not Listed Construction Materials	Manufactured Products
CDBG Formula Grants	All funds obligated on or after November 15, 2022	As of the date HUD obligates new FFA from FY24 appropriations	As of the date HUD obligates new FFA from FY25 appropriations	As of the date HUD obligates new FFA from FY25 appropriations
Choice Neighborhood, Lead Hazard Reduction, and Healthy Homes Production Grants	New FFA obligated by HUD on or after February 22, 2023	New FFA obligated by HUD on or after August 23, 2024	New FFA obligated by HUD on or after August 23, 2024	New FFA obligated by HUD on or after August 23, 2024
Recovery Housing Program (RHP) Grants	New FFA obligated by HUD on or after August 23, 2023	As of the date HUD obligates new FFA from FY24 appropriations	As of the date HUD obligates new FFA from FY25 appropriations	As of the date HUD obligates new FFA from FY25 appropriations
All HUD FFA except HOME, Housing Trust Fund, and Public Housing FFA used for maintenance projects	New FFA obligated by HUD on or after February 22, 2024	New FFA obligated by HUD on or after August 23, 2024	New FFA obligated by HUD on or after August 23, 2024	New FFA obligated by HUD on or after August 23, 2024
All HUD FFA	New FFA obligated by HUD on or after August 23, 2024	New FFA obligated by HUD on or after August 23, 2024	New FFA obligated by HUD on or after August 23, 2024	New FFA obligated by HUD on or after August 23, 2024



HUD Phased Implementation Waiver

- The HUD Phased Implementation Waiver establishes a schedule for when the BAP will apply to HUD programs.
- To apply the phased implementation waiver for CPD programs, a grantee needs to know:
 - The CPD funds used in the project,
 - The products used in the project, and
 - The obligation date of the CPD Funds.
 - Important note: For most CPD programs, the **date of obligation** is the date the grant agreement is signed by HUD.



Phased Implementation Examples

A participating jurisdiction contributes \$2,000,000 in HOME funds for construction of a multi-unit residential building. The project will use steel, construction materials, and manufactured products. ***The funds were obligated by HUD on July 15, 2023.***

- This project is an infrastructure project because it involves construction of a building.
- This project is funded using HOME, which is a covered CPD program under BABA.
- This project contains steel, construction materials, and manufactured products.
- HOME-funded projects will not be required to comply with the BAP until August 23, 2024.
- This project is not eligible for any general waivers.
- The BAP does not apply to this project because the funds were obligated by HUD before August 23, 2024 (the phased implementation date for HOME).



Phased Implementation Examples

A participating jurisdiction contributes \$2,000,000 in HOME funds for construction of a multi-unit residential building. The project will use steel, construction materials, and manufactured products. ***The funds are obligated by HUD on November 15, 2024.***

- This project is an infrastructure project because it involves construction of a building.
- This project is funded using HOME, which is a covered CPD program under BABA.
- This project contains steel, construction materials, and manufactured products.
- HOME-funded projects will be required to comply with the BAP for all materials for funds obligated by HUD on or after August 23, 2024.
- This project is not eligible for any general waivers.
- The BAP applies to this project because the funds were obligated by HUD on or after August 23, 2024 (the phased implementation date for HOME).





HUD General Waivers

HUD General Waivers

- HUD currently has four general waivers available, in addition to the Phased Implementation Waiver.
 - Exigent Circumstances Waiver
 - *De Minimis* and Small Grants Waiver
 - Tribal Recipients Waiver
 - Pacific Island Territories Waiver
- If any of these waivers applies, a grantee may waive the BAP for a project or a portion of a project.
- No formal request to HUD is needed to use these waivers.
- Grantees should maintain documentation that demonstrates the applicability of the waiver to a project, consistent with program regulations.



De Minimis and Small Grants Waiver

- Effective until November 23, 2027.
- *De Minimis* Waiver
 - The BAP can be waived for a portion of the products used in a project if the cost of those products comprises no more than 5 percent of the total cost of covered products used in the project (not to exceed \$1 million).
 - Example:
 - A grantee is using CDBG funding to construct a new playground and can find domestically produced products for nearly all the playground equipment, except for one \$20,000 slide. The total cost of the products used in the project is \$500,000.
 - The cost of the slide is less than 5% of the total cost of the materials, so the *de minimis* waiver can be applied to the slide and the BAP does not apply to the slide.
 - Note that the BAP still applies to the other products used in the project.



De Minimis and Small Grants Waiver

- Effective until November 23, 2027.
- Small Grants Waiver
 - The BAP can be waived for a project if the total project cost (including all sources of funding) is \$250,000 or less.
 - Example:
 - A grantee is using \$200,000 in ESG funding to rehabilitate the bathroom facilities in an emergency shelter. The grantee is also contributing \$25,000 in local funds. Because the total cost of the project (\$225,000) is less than the \$250,000 threshold, the Small Grants waiver applies.
 - The BAP can be waived for the entire project.



Exigent Circumstances Waiver

- Effective until November 23, 2027.
- The BAP may be waived if projects must be completed immediately to protect life, ensure safety, or prevent the destruction of property.
- Example:
 - Following a tornado, CDBG funds are used to repair public facilities made structurally unsound during the disaster. Stabilizing these buildings is critical to prevent further destruction of property.



Tribal Recipients and Pacific Island Territories Waivers

- Tribal Recipients Waiver
 - Effective until May 23, 2024.
 - The BAP is currently waived for all Federal financial assistance for infrastructure projects awarded to Tribes, Tribally Designated Housing Entities, and other Tribal Entities.
- Pacific Island Territories Waiver
 - Effective until February 15, 2025.
 - The BAP is currently waived for all Federal financial assistance for infrastructure projects in the Northern Mariana Islands, American Samoa, and Guam.





HUD Project-/Product-Specific Waivers

Project-/Product-Specific Waivers

- In addition to the general waivers, project-/product-specific waivers may be available for projects where the BAP would otherwise apply.
- There are three available categories of project-/product-specific waivers:
 - Public Interest
 - Nonavailability
 - Unreasonable Cost
- Generally, these waivers:
 - Should be targeted to specific products or categories of products.
 - May be time-limited: issued for a certain period of time, rather than for a specific project.
 - May be conditional with conditions that support the policies of BABA.



Project-/Product-Specific Public Interest Waivers

- A public interest waiver may be available when applying the BAP would be inconsistent with the public interest.
- Waiver requests for public interest waivers should:
 - Explain how waiving the BAP for the project or product serves the public interest.
 - Demonstrate definite impacts on the community if specific items, products, or materials are not utilized in an infrastructure project.



Project-/Product-Specific Nonavailability Waivers

- A nonavailability waiver may be available when a particular iron or steel product, construction material, or manufactured product is not produced in the United States in sufficient quantities or of a satisfactory quality.
- Waiver requests for nonavailability waivers should:
 - Demonstrate that the grantee has conducted market research and adequately considered qualified alternate items.
 - Describe the due diligence performed, including information, quotes, and/or responses from manufacturers, distributors, or suppliers.



Project-/Product-Specific Unreasonable Cost Waivers

- An unreasonable cost waiver may be available when applying the BAP will increase the cost of the overall project by more than 25 percent.
- Waiver requests for unreasonable cost waivers should:
 - Demonstrate that applying the BAP increases the total project cost by more than 25%.
 - Determine the additional cost of BAP-compliant products.
 - Determine the dollar amount to be waived.
 - Demonstrate that no domestic alternatives are available within the project budget.



Applying for a HUD Project-/Product-Specific Waiver

- Step 1: Contact CPDBABA@hud.gov for BABA technical assistance as needed.
- Step 2: Prepare a “[Build America Buy America Waiver Request](#)” with the information required by the Made in America Office (MIAO).
- Step 3: Submit a waiver application with all necessary information to HUD at BuildAmericaBuyAmerica@hud.gov.
- Step 4: Provide additional information as requested by HUD during the review process to proceed with public comment in the Federal Register, and final approval by MIAO.
- Step 5: HUD reviews waivers before they are posted to the Federal Register for public comment and sent to the MIAO for approval. If approved, the waiver is posted on MadeInAmerica.gov.





Compliance and Recordkeeping

Grant Agreement Language

- All FY23 grant agreements include BABA language.
 - *The Grantee must comply with the requirements of the Build America, Buy America (BABA) Act, 41 USC 8301 note, and all applicable rules and notices, as may be amended, if applicable to the Grantee’s infrastructure project. Pursuant to HUD’s Notice, “Public Interest Phased Implementation Waiver for FY 2022 and 2023 of Build America, Buy America Provisions as Applied to Recipients of HUD Federal Financial Assistance” (88 FR 17001), any funds obligated by HUD on or after the applicable listed effective dates, are subject to BABA requirements, unless excepted by a waiver.*
- This language must be included in the terms and conditions of all Federal awards, including subawards, contracts, and purchase orders for the work performed or products supplied for infrastructure projects to ensure compliance with BABA.
- This language can be found in the “Special Conditions” section of your grant agreement, and in Addendum 3 of Notice CPD-23-12.



Recordkeeping

- What should grantees document?
 - Document the process used to analyze if the BAP applies to a project using the approach described in Notice CPD-23-12.
 - Document use of general waivers.
 - Document justification for project-/product-specific waivers.
- BABA records should be consistent with existing records retention requirements for each CPD program.
- If no program-specific records requirements exist, the CPD grantee may follow “retention requirements for records” under 2 CFR 200.334, as applicable to Federal grants.
- HUD is developing additional guidance about BABA reporting requirements in CPD information systems.





Applying the BAP to Analysis

Applying the BAP

- When planning a project, it is important to determine early on whether the BAP applies.
- If the project is an infrastructure project, there are three possible outcomes. A grantee must:
 - Comply with the BAP,
 - Utilize one of HUD's general waivers, or
 - Obtain a project-specific waiver to exclude the project from the BAP.
- The next slide illustrates the analysis process outlined in the CPD BABA Implementation Notice.



Does the BAP Apply to Your Project?

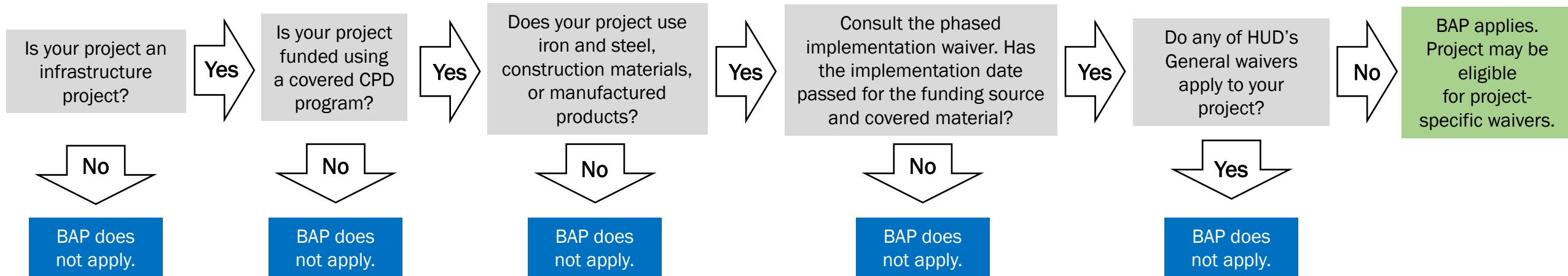

Example: Does the BAP Apply?

A participating jurisdiction contributes \$2,000,000 in HOME funds for new construction of a multi-unit residential building. The project will use steel, construction materials, and manufactured products. **The funds are obligated by HUD on November 15, 2024.**

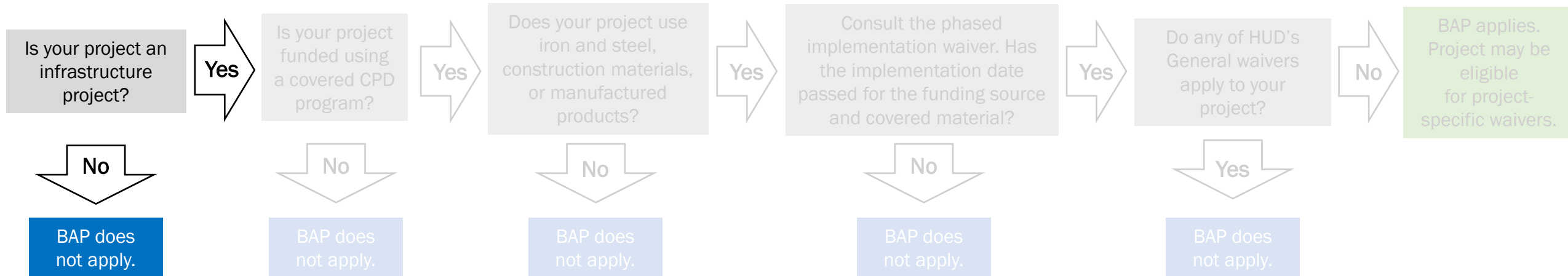

This project is an infrastructure project because it is construction of a building.

Example: Does the BAP Apply?

A participating jurisdiction contributes \$2,000,000 in HOME funds for new construction of a multi-unit residential building. The project will use steel, construction materials, and manufactured products. **The funds are obligated by HUD on November 15, 2024.**

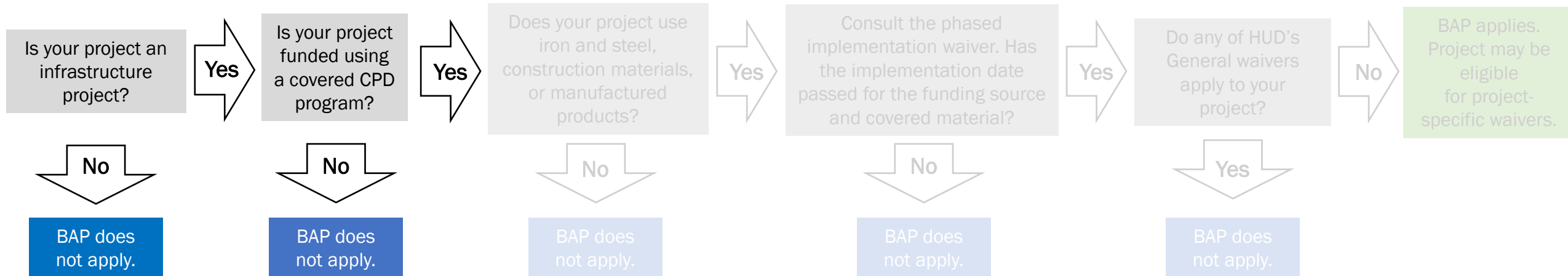

**This project is an infrastructure project because it is construction of a building.
This project is funded using HOME, which is a covered CPD program under BABA.**

Example: Does the BAP Apply?

A participating jurisdiction contributes \$2,000,000 in HOME funds for new construction of a multi-unit residential building. The project will use steel, construction materials, and manufactured products. **The funds are obligated by HUD on November 15, 2024.**

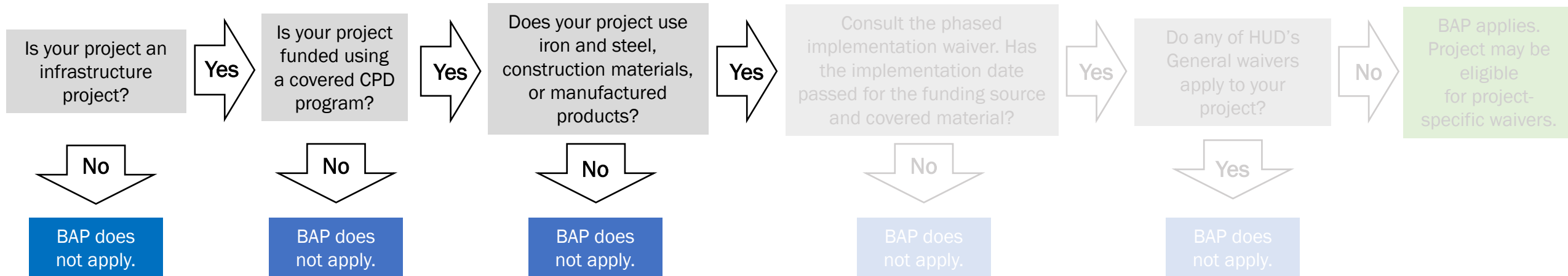

**This project is an infrastructure project because it is construction of a building.
This project is funded using HOME, which is a covered CPD program under BABA.
This project contains steel and construction materials.**

Example: Does the BAP Apply?

A participating jurisdiction contributes \$2,000,000 in HOME funds for new construction of a multi-unit residential building. The project will use steel, construction materials, and manufactured products. ***The funds are obligated by HUD on November 15, 2024.***

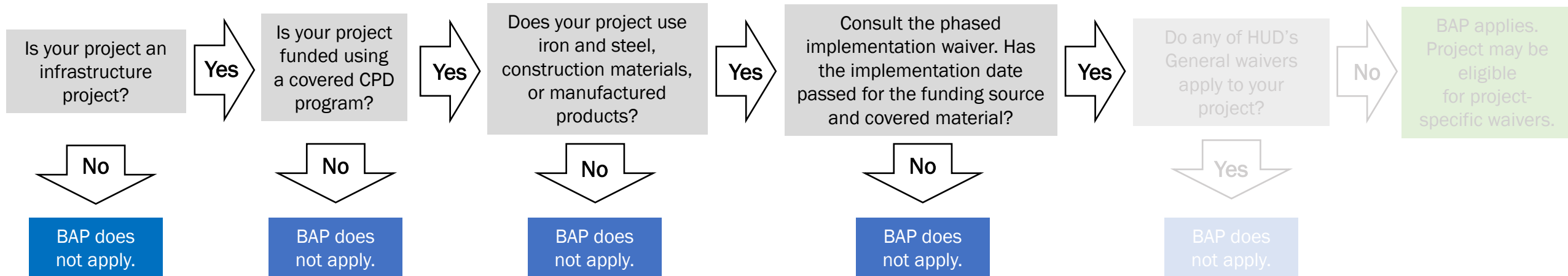

This project is an infrastructure project because it is construction of a building.

This project is funded using HOME, which is a covered CPD program under BABA.

This project contains steel and construction materials.

HOME projects using iron and steel, construction materials, and manufactured products must comply with the BAP for funds obligated by HUD on or after August 23, 2024.

Example: Does the BAP Apply?

A participating jurisdiction contributes \$2,000,000 in HOME funds for new construction of a multi-unit residential building. The project will use steel, construction materials, and manufactured products. ***The funds are obligated by HUD on November 15, 2024.***

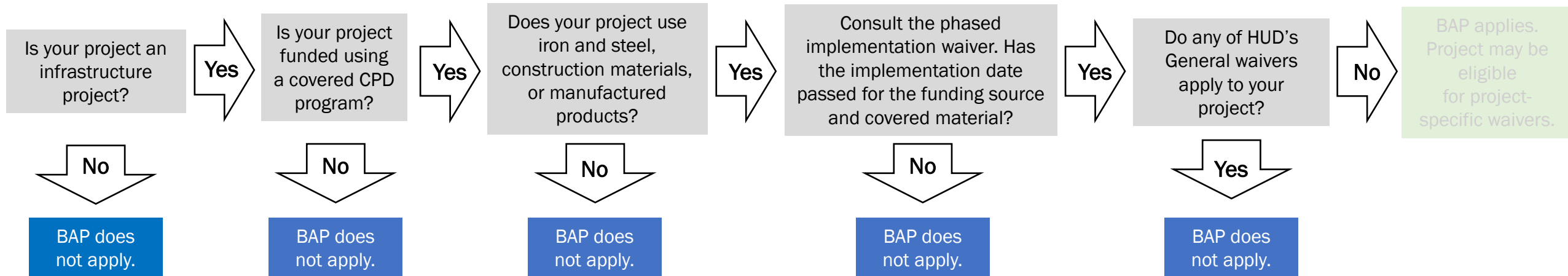

This project is an infrastructure project because it is construction of a building.

This project is funded using HOME, which is a covered CPD program under BABA.

This project contains steel and construction materials.

HOME projects using iron and steel, construction materials, and manufactured products must comply with the BAP for funds obligated by HUD on or after August 23, 2024.

This project is not otherwise covered under an existing HUD general waiver.

Example: Does the BAP Apply?

A participating jurisdiction contributes \$2,000,000 in HOME funds for new construction of a multi-unit residential building. The project will use steel, construction materials, and manufactured products. ***The funds are obligated by HUD on November 15, 2024.***

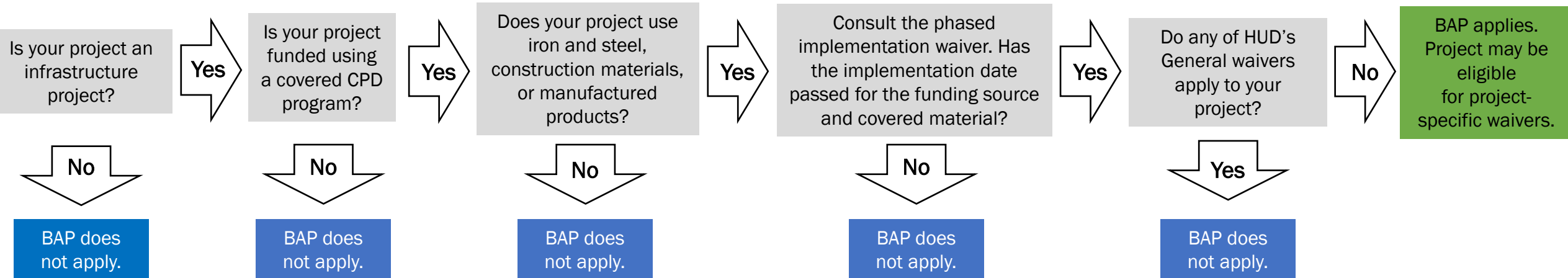

The BAP may apply to the iron and steel, construction materials, and manufactured products used in this project unless a project- or product-specific waiver is issued by the Office of Management and Budget's Made In America Office.



FAQ's and Resources

Key Takeaways

- All infrastructure projects funded through covered CPD programs must comply with BABA.
 - Applies to CPD grantees, subrecipients, contractors and vendors.
- Iron and steel, construction materials, and manufactured products used in infrastructure projects must be produced in the United States.
- CPD programs are subject to the Buy America Preference based on HUD's Phased Implementation Schedule.
- HUD has issued general waivers that may apply to certain projects.
- Grantees may request project-/product-specific waivers through HUD's waiver process.
- Implementation and Compliance Should be documented, as described in Notice CPD-23-12.



FAQ #1 – When does the BAP apply to HOME & HTF?

The Buy America Preference applies to HOME and HTF funds obligated on or after August 23, 2024, used for infrastructure projects that require the purchase of

1. iron or steel,
2. construction materials, and
3. manufactured products.

- HOME and HTF grants obligated via grant agreements **signed by HUD prior to August 23, 2024, are not subject to the BAP.**
- HOME and HTF grants obligated via grant agreements **signed by HUD on or after August 23, 2024, are subject to the BAP.**



FAQ #2 – How does the BAP apply to projects with mixed PY funds?

HOME and HTF funds will be subject to the BAP when obligated by HUD on or after August 23, 2024, unless covered by an applicable waiver.

- Infrastructure projects that use funds from HUD before BABA became applicable do not require the application of the BAP.
- If the PJ adds other PY funds that are subject to the BAP to a project, the entirety of the project is required to comply with the BAP unless HUD grants a waiver.



FAQ #3 – How does a PJ certify a project meets BABA requirements?

The BAP must be included in all subawards, contracts, and purchase orders for the work performed or products supplied under the HOME or HTF grant.

PJs should include the BABA language from their grant agreement in all subrecipient and bid contract documents to ensure BABA compliance by subrecipients, developers, and/or contractors.

Defer to available manufacturer certifications and product information to demonstrate compliance, which may vary.



RE: BABA Certification

To Whom It May Concern;

This letter is to certify that all PVC pipe manufactured by Diamond Plastics Corporation is compliant with the provisions set forth in the Build America, Buy America (BABA) Act. All PVC pipe is compounded and produced with integral Rieber gaskets at the following locations;

Casa Grande, Arizona
Golconda, Nevada
Grand Island, Nebraska
Lubbock, Texas
Macon, Georgia
Muncie, Indiana
Plaquemine, Louisiana

Items subject to BABA are classified to one of three construction materials. Guidance from the Office of Federal Register Vol. 87, No. 144 states “Items that have been combined together through a manufacturing process, listed materials combined with a material that is not treated as manufactured products, rather than as a sliding window should be treated as a manufactured



CERTIFICATION OF COMPLIANCE WITH BUILD AMERICA, BUY AMERICA (BABA) PROVISIONS

To Whom It May Concern:

This letter certifies that Performance Pipe, a division of Chevron Phillips Chemical LP, produces all of its pipe and molded fittings products in seven manufacturing plants located throughout the United States. Performance Pipe’s manufacturing facilities are located in: Bloomfield, IA; Brownwood, TX; Hagerstown, MD; Knoxville, TN; Pryor, OK; Reno, NV; and Startex, SC.

Therefore, for purposes of compliance with Public Law 117-58, *Build America, Buy America (BABA)* included in the Infrastructure Investment & Jobs Act (IIJA) – also referred to as the Bipartisan Infrastructure Law (BIL) – under Title IX, Subtitle A, Part I – Buy America Sourcing Requirements, all Performance Pipe’s pipe and molded fittings sold for use in the construction, alteration, maintenance, or repair of projects are produced in the United States.



California: 14722 Spring Avenue, Santa Fe Springs, CA 90670
13827 Carmenita Road, Suite D, Santa Fe Springs, CA 90670
Texas: 2051/2100 Reliance Pkwy, Bedford, TX 76201
3001 East Pioneer Parkway, Arlington, TX 76010
www.polycoatusa.com | WPSales@polycoatusa.com | 562.802.8834

CERTIFICATE OF COMPLIANCE WITH BUILD AMERICA, BUY AMERICA (BABA) PROVISIONS

To Whom it May Concern,

This letter certifies that Polycoat Products, a division of American Polymers Corp., produces all of its materials in four manufacturing plants located in the United States. Polycoat Products’ manufacturing facilities are located in: Santa Fe Springs, CA (Carmenita plant); Santa Fe Springs, CA (Spring plant); Bedford, TX; and Arlington, TX.

Key Takeaway

Industries are providing information that demonstrate products are BABA compliant.

VALVE Products

Water and Wastewater Valves

- ▶ Air Release / Vacuum Valves ▼
- ▶ Automatic Control Valves ▼
- ▶ Backflow Preventers ▼
- ▶ Break Off Plugs
- ▶ Butterfly Valves ▼
- ▶ C
- ▶ C

**PROUDLY
MADE IN
THE USA**

This product, like many other SP products, was made in the United States of America



Build America, Buy America (BABA) Act Valve Products

Flomatic is proud to serve as a **Build America, Buy America (BABA)** compliant manufacturer within the *manufactured products category*.

Flomatic works closely with several United States foundries to produce different grades of ferrous castings to meet **BABA requirements**. Please consult factory for availability and confirmation. Flomatic will provide a signed letter of compliance to the BABA provision if possible.

PLEASE NOTE: To ensure BABA documentation is appropriately captured and maintained throughout the manufacturing process, BABA (along with any other regulatory requirements) **must be specified at the time of quotation**



Product details

- Package Dimensions :** 14.1 x 12.6 x 8.8 inches; 0.01 Ounces
- Item model number :** 378570000
- Date First Available :** November 3, 2009
- Manufacturer :** Bel-Art Products
- ASIN :** B002VBW7XY
- Country of Origin :** USA
- Best Sellers Rank:** #1,221,753 in Industrial & Scientific (See Top 100 in Industrial & Scientific)
#37 in Lab Multichannel Pipettors



Key Takeaway

Certifications of BABA compliance may be found on manufacturer websites when sourcing the items needed to complete the project.

Resources

- [CPD Notice 23-12](#)
- CPD BABA [Technical Assistance](#)
 - BABA Case Study Webinar – February 2024
 - BABA Quick Guide & Webinar for HOME and HTF Grantees – April 23, 2024
- [BABA on HUD.gov](#)
 - More information on project-specific waiver process
- BABA Regulations: [2 CFR 184](#)
- [OMB Memorandum M-24-02](#)





Questions?
Please submit to the [BABA AAQ](#) on
HUDExchange.